

Lithium-ion Rechargeable Specification

Product name: LiFePO4 battery

Product Item: IFR-9.6V-1800mAH-BP

Specification Approved	PREPARED	
	CHECKED	
	APPROVED	

Revised List

Version No	Description of Revise	Date	Prepared
A0	New Publish	2023-4-21	Joan Li
A1	Addition Charge Parameters	2023-5-19	Joan Li

SHENZHEN HIMAX ELECTRONICS CO.,LTD.

Add: Building B, Nantong Avenue NO.5, Tongle Community, Baolong Street,
 Longgang Shenzhen China

Tel: 86 (0) 755-25629920 Fax: 86 (0) 755-25629925

www.himaxelectronics.com

www.himaxbattery.com

Content

1. Scope.....	P.3
2. Model.....	P.3
3. Reference standard.....	P.3
4. Specification.....	P.3~4
5. PCM Parameter.....	P.4
6. Product Circuit diagram	P.5
7. Electrical Performance & test condition	P.5~6
8. Mechanical Performance	P.6
9. Cell Safety Performance	P.7
10. Delivery/Packing/Storage and Shipment	P.7
11. Battery Pack Feature	P.8
12. Period of Warranty	P.9
13. Warnings	P.9
14. Battery operation instruction	P.9~10
15. Others	P.10

1. Scope

This product specification describes HIMAX's LiFePO₄ battery. Please using the test methods that recommend in this specification. If you have any opinions or advice about the test items and methods, please contact us.

2. Model

Model: IFR-9.6V-1800mAH-BP

3. Reference standard

The standard reference GB/T18287-2013, UL1642 and CE61960 technology standards compiled.

4. Specification

	Item	Rating	Note
Cell	Type	LiFePO ₄ Battery	
	Cell Model	18650-1800	
	Nominal Capacity	1800mAh	Discharge: 0.2C Cut-off Voltage:2.0V
	Minimum Capacity	1750mAh	Discharge: 0.2C Cut-off Voltage: 2.0V
	Nominal voltage	3.2V	
	Internal Impedance	≤35mΩ	
	Dimension	Max 18.6x65.3mm	
	Weight	Approx 42g	
Battery pack	Pack Method	3S1P	
	Nominal Capacity	1800mAh	Discharge: 0.2C Cut-off Voltage:5V
	Minimum Capacity	1700mAh	Discharge: 0.2C Cut-off Voltage: 5V
	Nominal Voltage	9.6V	
	Energy	17.28Wh	
	Maximum Charge Voltage	5.25V for Type-C port 10.95V for (P+, P-)	
	Discharge cut-off voltage	5V	
	Charge Method	CC/CV	
	Max. Charge Current for Type-C port	0.4A	
	Max. Charge Current for (P+, P-)	2A	
	Standard Discharge Current	0.4A	

	Max. Continues Discharge current	2A	
	Cycle Life	2000 times (次)	80% SOC
	Internal Impedance	≤200mΩ	
	Dimension	86*61*33mm	
	Output Wire	/	/
	Output Connector	USB type C	
	Weight	Approx 140g	
	Working Temperature Range	Charge: 0°C~45°C Discharge: -20°C~60°C	
	Storage Temperature	-10°C~45°C	

5. PCM Parameter

No.	Item		Standard
1	Charge Current		5V2A
2	Discharge Current		≤1A
3	Overcharge	Over-Charge Detect Voltage	3.75V±0.05V
		Over-Charge Delay Time	1.7-2.3S
		Over-Charge Reset Voltage	3.5V±0.1V
4	Over-discharge	Over-Discharge Detect Voltage	2.50V±0.1V
		Over-Discharge Delay Time	1.7-2.3S
		Over-Discharge Reset Voltage	2.8V±0.1V
5	Over-current	Over-Current Detect Current1	2.5±0.5A
		Over-Current Delay Time1	2S
		Over-Current Detect Current2	3±0.5A
		Over-Current Delay Time3	1S
		Reset	Release load
6	Short Circuit	Detect Status	External Short Circuit
		Reset	Release load
7	Resistance		≤100mΩ

6. Product Circuit diagram

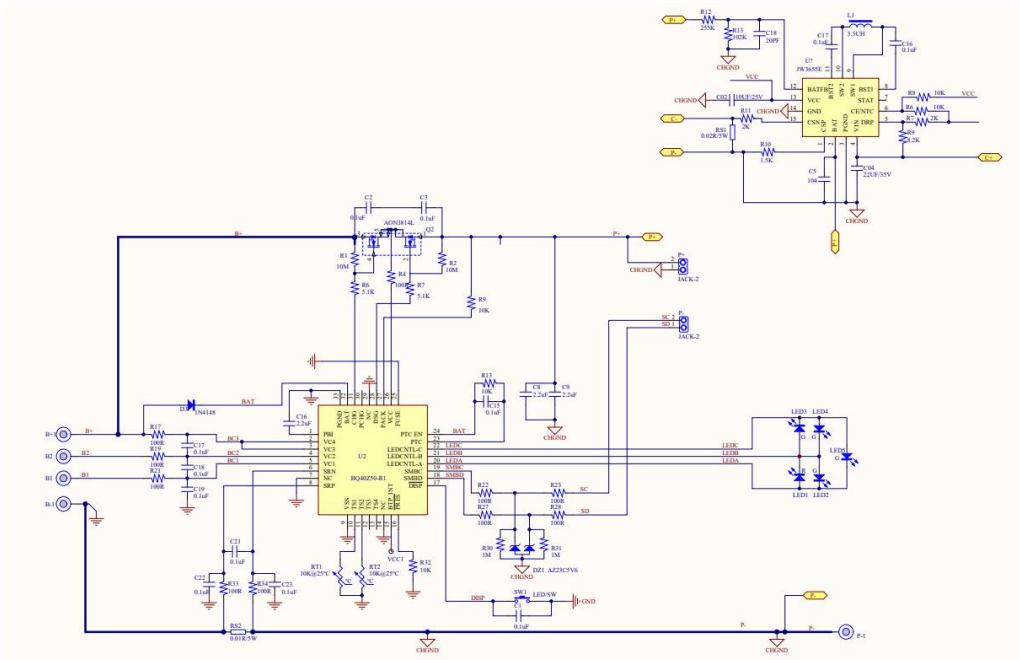

7. Electrical Performance & test condition

7.1 Standard Test Condition

The battery shall be evaluated within 1 month from the arrival date.

Unless otherwise stated in these specifications, the following test shall be carried out in an ambient temperature of $20 \pm 5^\circ\text{C}$, relative humidity of $65 \pm 20\%$,

Discharge capacity when the battery is discharged at 0.4A to 5V after being standard charged. Five cycles are permitted for this test. The test shall be terminated at the end of the first cycle which meets the requirement.

7.2 Testing Instrument or Apparatus

7.2.1 Dimension Measuring Instrument

The dimension measurement shall be implemented by instruments with equal or more precision scale of 0.01mm specified.

7.2.2 Voltmeter and Ammeter

Voltmeters and ammeters shall be equal or more precision instruments of $10\text{K}\Omega/\text{V}$ and 0.01Ω .

7.2.3 Impedance Meter

Impedance shall be measured by a sinusoidal alternating current method (1kHz LCR meter).

7.3 Standard Charge

Standard charge means charging for 6hours using 5V/2A charger.

7.4 Standard Discharge

Standard discharge means discharging at 0.4A down to 5V.

7.5 Electrical Performance

Item	Condition	Specification
Open-Circuit Voltage	The open-circuit voltage shall be measured within 24hours after standard charge.	≥10.2V
Battery Capacity	The discharge time at 0.4A shall be measured after standard charge at 20±5°C and rest 30mins.	≥95%
Cycle Life	The discharge time on standard discharge shall be measured after 2000 cycles of standard charge and discharge at 20±5°C.	≥80%
Charge(capacity) retention	The discharge time at 0.4A shall be measured after standard charge and then storage at 20±5°C for 28days.	≥95%
Temperature Characteristic1	After standard charging at 20±5°C, laying the battery at 55°C for 2hours, then discharge at 0.4A to 5V, record the discharge time.	≥85%
Temperature Characteristic2	After standard charging at 20±5°C, laying the battery at -10°C for 4hours, then discharge at 0.4A to 5V, record the discharge time .	≥60%

8. Mechanical Performance

Item	Condition	Specification
Crush Test	A battery is to be crushed between two flat surfaces. The force for the crushing is to be applied by a hydraulic ram with a 32mm diameter piston. The crushing is to be continued until a pressure reading of 17.2mmPa is reached on the hydraulic ram, applied force of 13kN. Once the maximum pressure has been obtained it is to be released.	No fire, No explosion
Drop Test	The battery has only two axes of symmetry in which case only two directions shall be tested. The battery is to be dropped from a height of 1 meter twice onto concrete ground.	No explosion, No fire, No smoke
Vibration	A full-charged battery is to be subjected to simple harmonic motion with an amplitude of 1.6mm total maximum excursion. The frequency is to be varied at the rate of 1 hertz per minute between 10 and 55 hertz. The cell shall be vibrated for 30 minutes per axis o XYZ axes.	No leakage No Fire No explosion

9. Cell Safety Performance

Item	Condition	Specification
Over charge	At 20±5℃, charging battery with constant current 1C to voltage 4V, then with constant voltage 4V till current decline to 0.	No explosion No fire
Over discharge	At 20±5℃, the cell are fully charged with standard charging method and standby at least 1 hour. The cell should be discharged at a current of 1C for 2.5h.	No explosion No fire No leakage
Short-circuit	At 20±5℃, The cells are fully charged with standard charging method and standby at least 1hour. Positive and negative terminal connect with wire (maximum load of 50mΩ) to cause short circuit until its voltage is lower than 0.1V or cell temperature on the surface is back to room temperature ±10℃.	No explosion, No fire The temperature of the surface of the cell are lower than 150℃
Heating	Battery is heated in a circulating air oven at a rate of 5±2℃ per min to 130℃, an then placed 30 mins under 130℃.	No explosion, No fire

10. Delivery/Packing/Storage and Shipment

10.1 Approx. 30-70% charged before delivery, Shipment voltage:9.6-10.2V.

10.2 The battery should be checked the voltage, resistance and the function of protective circuit before shipment.

10.3 Packing and Shipping

10.3.1 The battery should be transported to the factory assembly, to pay special attention to the packing, in order to avoid transport stress.

10.3.2 The battery should be in a half state of charge packaging boxes for transport, in the transport process, prevent severe vibration, shock, extrusion, prevent the sun and rain, should be in automobile, train, ship, airplane and other forms.

10.4 Abnormal Condition

Do not use the battery when it's smell like abnormal cell electrolyte because of transport stress, sag, short circuit or any other.

11. Battery Pack Feature

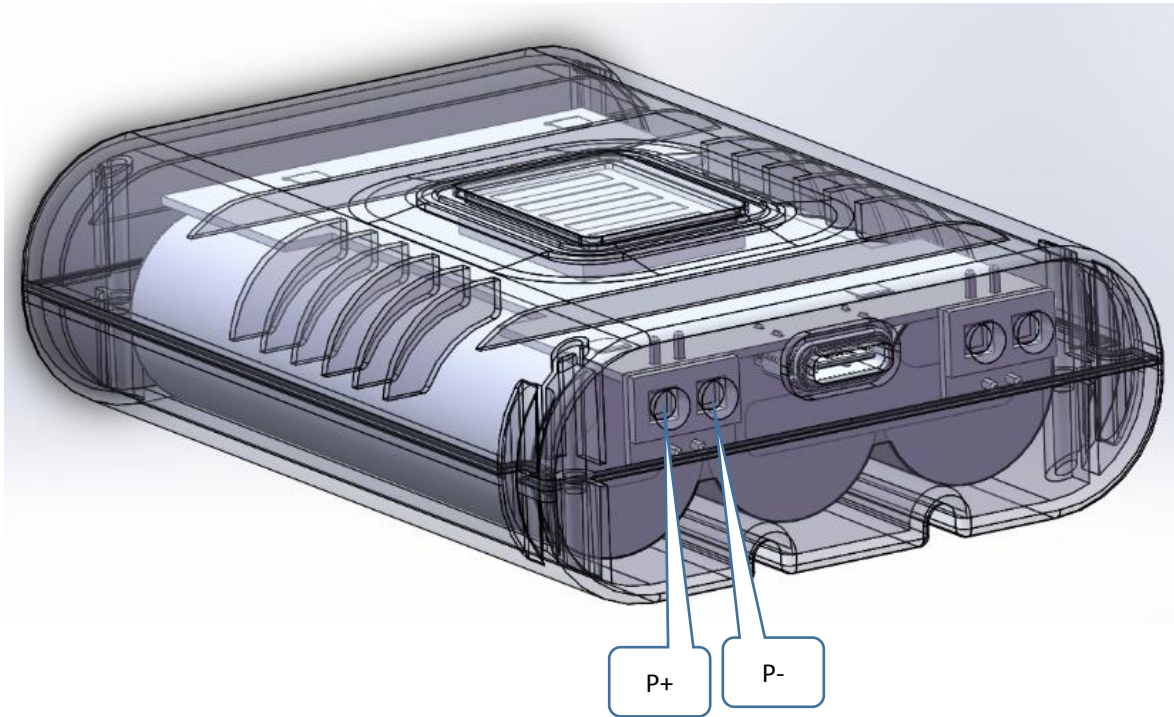

HMS Model	IFR-9.6V-1800mAH-BP			
File No.	HLFGB03 1A80-1448		Signature	Date
Revision	A1	Drawn by	Joan Li	2023-05-19

12. Period of Warranty

The period of warranty is 1 years from the date of shipment. HIMAX guarantees to give a replacement in case of battery with defects proven due to manufacturing process instead of the customer abuse and misuse.

13. Warnings

To prevent the possibility of the battery from leaking, heating, fire, Please READ this specification carefully before usage and observe the following precautions:

- Ⓞ When recharging, use the LiFePO4 battery charger specifically for that purpose.
- Ⓞ Do not strike battery with any sharp edge parts, such as Ni-tabs, pins and needles.
- Ⓞ Do not immerse the battery in water and seawater.
- Ⓞ Do not use and leave the battery near a heat source as fire or heater.
- Ⓞ Do not reverse the positive and negative terminals.
- Ⓞ Do not connect the battery to an electrical outlet.
- Ⓞ Do not discard the battery in fire or heat it.
- Ⓞ The battery tabs are not so stubborn especially for aluminum tab. Do not bend tab.
- Ⓞ Do not short-circuit the battery by directly connecting the positive and negative terminal with metal object.
- Ⓞ Do not transport and store the battery together with metal objects such as necklaces, hairpins etc.
- Ⓞ Do not knock or throw, trampling battery etc.
- Ⓞ Do not directly solder the battery and pierce the battery with a nail or other sharp object.
- Ⓞ Do not split the battery without permission.

14. Battery operation instruction

14.1 Charging

Charging current: Do not surpass the biggest charging current which in this specification.

Charging voltage: Do not surpass the highest voltage which in this specification.

Charge temperature: The charge temperature is in according to this specification.

14.2 Discharging

Discharge current: Do not surpass the biggest discharge current which in this specification.

Discharging with a higher current may result in the capacity fade and over-heat.

Discharge temperature: The discharge temperature is in according to this specification.

14.3 Over-discharges

After the short time excessively discharges charges immediately cannot affect the use, but the long

time excessively discharges can cause the battery the performance, battery function losing. The battery long-term has not used, has the possibility to be able to be at because of its automatic flashover characteristic certain excessively discharges the condition, for prevented excessively discharges the occurrence, the battery should maintain the certain electric quantity.

14.4 Storing the Batteries

The battery should store in the product specification book stipulation temperature range. If has surpasses above for 3 months the long time storage, suggested you should carry on additional charge to the battery.

14.5 Please do not continuously charge the battery over 8hours.

15.Others

©The customer is requested to contact HIMAX in advance, if and when the customer needs other applications or operating conditions than those described in this document. Additional experimentation may be required to verify performance and safety under such conditions.

©HIMAX will take no responsibility for any accident when the battery is used under other conditions than those described in this Document.

©HIMAX will inform, in a written form, the customer of improvement(s) regarding proper use and handing of the battery, if it is deemed necessary.