

磷酸铁锂电池规格书
Lithium-ion Rechargeable Specification

产品名称: 磷酸铁锂电池

Product name: LiFePO4 battery

产品型号: LiFePO4 32700 12.8V 100Ah

Product Item: LiFePO4 32700 12.8V 100Ah

核准 Authorized	编制 Prepared

修订记录

版本号 Version No	修改描述 Description of Revise	日期 Date	编制 Prepared
A	新版发行 New Publish	2019/3/28	

SHENZHEN HIMAX ELECTRONICS CO.,LTD.

深圳市海马士电子有限公司

Add: Bldg C, Huaming Industrial zone, Huaming Road Dalang, Longhua, Bao'an, Shenzhen, China.

广东省深圳市龙华新区大浪街道办华明工业园 C 栋

Tel: 86 (0) 755-25629920 Fax: 86 (0) 755-25629925

www.himaxelectronics.com

www.himaxbattery.com

目录

Content

1. 适用范围 Scope.....	P.3
2. 产品型号 Model.....	P.3
3. 引用标准 Reference standard.....	P.3
4. 产品规格 Specification.....	P.3~4
5. 保护板参数 PCM Parameter.....	P.4~5
6. 电路原理图 Product Circuit diagram	P.5
7. 电池性能及测试条件 Electrical Performance & test condition	P.5~6
8. 机械性能 Mechanical Performance	P.7
9. 电芯安全性能 Cell Safety Performance	P.7~8
10. 出货/包装/储存及运输 Delivery/Packing/Storage and Shipment	P.8
11. 电池外观 Battery Pack Feature	P.9
12. 保质期 Period of Warranty	P.10
13. 警告 Warnings	P.10
14. 电池操作说明 Battery operation instruction	P.11
15. 其他事项 Others	P.12

1. 适用范围 Scope

本产品规格书适用于深圳市海马士电子有限公司生产的磷酸铁锂电池主要性能指标的描述。用户请务必严格按照规格书中的测试或使用方法进行测试或使用，如对表中的测试项目或测试方法有异议，请与供应方协商解决。

This product specification describes HIMAX's LiFePO₄ battery. Please using the test methods that recommend in this specification. If you have any opinions or advice about the test items and methods, please contact us.

2. 产品型号 Model

Model: LiFePO₄ 32700 12.8V 100Ah

3. 引用标准 Reference standard

本标准参考国标 GB/T18287-2013、UL1642 以及 CE61960 等技术标准规范编制而成。

The standard reference GB/T18287-2013, UL1642 and CE61960 technology standards compiled.

4. 产品规格 Specification

	项目 Item	参数 Rating	备注 Note
电芯 Cell	电池类型 Type	LiFePO ₄ Battery	
	电芯型号 Cell Model	32700	
	标称容量 Nominal Capacity	6.3Ah	Discharge: 0.2C Cut-off Voltage:2.5V
	最小容量 Minimum Capacity	6Ah	Discharge: 0.2C Cut-off Voltage: 2.5V
	标称电压 Nominal voltage	3.2V	
	内阻 Internal Impedance	≤25mΩ	
	尺寸 Dimension	Max. 32.5x70.5mm	
	重量 Weight	Approx.148g	
电池组 Battery pack	组合方式 Pack Method	4S16P	
	标称容量 Nominal Capacity	100Ah	Discharge: 0.2C Cut-off Voltage:10V
	最小容量 Minimum Capacity	95Ah	Discharge: 0.2C Cut-off Voltage: 10V
	标称电压 Nominal Voltage	12.8V	
	能量 Energy	1280Wh	
	充电电压 Charge Voltage	14.6V	
	放电截止电 Discharge cut-off voltage	10V	
	充电方式 Charge Method	CC/CV	

标准充电电流 Standard Charge Current	20A	
最大充电电流 Max. Charge Current	50A	
标准放电电流 Standard Discharge Current	20A	
最大持续放电电流 Max. Continues Discharge current	100A	
循环寿命 Cycle Life	2000 times (次)	70% SOC 80%DOD
内阻 Internal Impedance	≤100mΩ	
尺寸 Dimension	330*173*215±5mm	
引出线 Output Wire	/	
插头 Output Connector	/	
重量 Weight	Approx.12.5kg	
工作温度范围 Working Temperature Range	Charge: 0°C--45°C Discharge: -20°C--60°C	
储存温度 Storage Temperature	-10°C--45°C	

5. 保护板参数 PCM Parameter

No.	Item	Standard
1	充电电流 Charge Current	≤100A
2	放电电流 Discharge Current	≤100A
3	均衡电流 Balanced Current	180±10mA
	均衡电压 Balanced Voltage	3.60±0.05V
4	过充保护电压 Over-Charge Detect Voltage	3.85-3.95 V
	过充延时 Over-Charge Delay Time	0.5-2S
	过充恢复电压 Over-Charge Reset Voltage	3.50-3.70 V
5	过放保护电 Over-Discharge Detect Voltage	1.9-2.1 V
	过放延时 Over-Discharge Delay Time	10-400mS
	过放恢复电 Over-Discharge Reset Voltage	2.60-2.80V
6	过流保护电流 Over-Current Detect Current	250-350 A
	过流延时 Over-Current Delay Time	5-60ms

		条件 Reset	Release load
7	Short Circuit	Detect Status	External Short Circuit
		Reset	Release load
8	Resistance		$\leq 20m\Omega$

6. 电路原理图 Product Circuit diagram

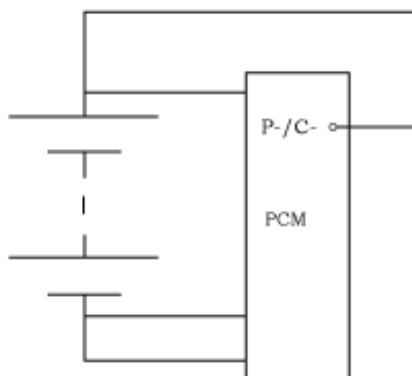

7. 电池性能及测试条件 Electrical Performance & test condition

7.1 标准测试条件 Standard Test Condition

电池应在到货日期一个月内测试，除非规格书中特别注明，本规格书规定的测试条件为：温度： $20\pm 5^{\circ}\text{C}$ ，相对湿度： $65\pm 20\%$ ，标准充电后，20A 放电到截止电压 10V 的容量，为电池的标准容量，允许 5 次循环，其中一次达到最小容量即为合格。

The battery shall be evaluated within 1 month from the arrival date.

Unless otherwise stated in these specifications, the following test shall be carried out in an ambient temperature of $20\pm 5^{\circ}\text{C}$, relative humidity of $65\pm 20\%$,

Discharge capacity when the battery is discharged at 20A to 10V after being standard charged. Five cycles are permitted for this test. The test shall be terminated at the end of the first cycle which meets the requirement.

7.2 测试仪器 Testing Instrument or Apparatus

7.2.1 尺寸测量工具 Dimension Measuring Instrument

测量尺寸的仪器精度应大于等于 0.01mm.

The dimension measurement shall be implemented by instruments with equal or more precision scale of 0.01mm specified.

7.2.2 万用表和安培计 Voltmeter and Ammeter

测量电池电压时万用表内阻应大于 10KΩ/V，电流表及电线在内的总内阻应小于 0.01Ω.

Voltmeters and ammeters shall be equal or more precision instruments of 10KΩ/V and 0.01Ω.

7.2.3 内阻仪 Impedance Meter

内阻测试仪测试原理应为交流阻抗法(1kHz LCR).

Impedance shall be measured by a sinusoidal alternating current method (1kHz LCR meter).

7.3 标准充电 Standard Charge

锂离子电池专用充电器 14.6V/20A，充电时间约 6 小时.

Standard charge means charging for 6hours using 14.6V/20A charger.

7.4 标准放电 Standard Discharge

电池以 0.2C 恒流放电到截止电压 10V.

Standard discharge means discharging at 0.2C down to 10V.

7.5 电池性能 Electrical Performance

名称 Item	测试方法及条件 Condition	要求 Specification
开路电压 Open-Circuit Voltage	标准充电后，24 小时内测量的开路电压。 The open-circuit voltage shall be measured within 24hours after standard charge.	≥13.2V
电池容量 Battery Capacity	标准充电后,搁置 1 小时,然后用 20A 电流放电至截止电压，记录放电时间。 The discharge time at 20A shall be measured after standard charge at 20±5°C and rest 30mins.	≥95%
循环寿命 Cycle Life	在 20±5°C 状态下,用 20A 恒流充电至充电电压,再恒压直至充电电流≤0.02C；搁置 1 小时,再用 20A 电流放电至截止电压；又搁置 1 小时,循环 2000 次，记录放电时间. The discharge time on standard discharge shall be measured after 2000 cycles of standard charge and discharge at 20±5°C.	≥70%
荷电保持能力 Charge(capacity) retention	在 20±5°C 状态下,标准充饱电后,电芯搁置 28 天,然后用 20A 放电至截止电压,记录放电时间。 The discharge time at 20A shall be measured after standard charge and then storage at 20±5°C for 28days.	≥95%
温度性能 1 Temperature Characteristic1	标准充电后，在 55±2°C 条件下贮存 2h，然后用 20A 放电至截止电压，记录放电时间。 After standard charging at 20±5°C, laying the battery at 55°C for 2hours, then discharge at 20A to 10V, record the discharge time.	≥85%

温度性能 2 Temperature Characteristic2	标准充电后, 在-10±2℃条件下贮存 4h, 然后用 20A 放电至截止电压, 记录放电时间. After standard charging at 20±5℃, laying the battery at -10℃ for 4hours, then discharge at 20A to 10V, record the discharge time .	≥60%
--	--	------

8. 机械性能 Mechanical Performance

名称 Item	测试条件 Condition	要求 Specification
挤压测试 Crush Test	将电池放在平板间进行挤压, 其压力通过一个直径位 32mm 的液压缸进行施压, 直到压力达到 17.2Mpa,施加的压力为 13KN,当达到压力后泄压. A battery is to be crushed between two flat surfaces. The force for the crushing is to be applied by a hydraulic ram with a 32mm diameter piston. The crushing is to be continued until a pressure reading of 17.2mmPa is reached on the hydraulic ram, applied force of 13kN. Once the maximum pressure has been obtained it is to be released.	不起火 不爆炸 No fire, No explosion
跌落测试 Drop Test	将电池样品由高度 1m 的位置自由跌落到置于水泥地面上的钢板上, 并从圆柱电池的两个轴向正负方向(四个方向) 每个方向自由跌落 1 次. The battery has only two axes of symmetry in which case only two directions shall be tested. The battery is to be dropped from a height of 1 meter twice onto concrete ground.	不爆炸 不起火 不冒烟 No explosion, No fire, No smoke
振动测试 Vibration	将充满电后的电池固定在振动台上, 沿 X,Y,Z 三个方向各振动 30 分钟,振幅 1.6mm 频率将以每分钟 1HZ 的速度变化在 10 到 55HZ 之间. A full-charged battery is to be subjected to simple harmonic motion with an amplitude of 1.6mm total maximum excursion. The frequency is to be varied at the rate of 1 hertz per minute between 10 and 55 hertz. The cell shall be vibrated for 30 minutes per axis o XYZ axes.	不漏液 不起火 不爆炸 No leakage No Fire No explosion

9. 电芯安全性能 Cell Safety Performance

名称 Item	测试条件 Condition	要求 Specification
过充电测试 Over charge	在 20±5℃状态下,电池用 1C 电流充电至 4V,然后恒压 4V 让电流下降接近为 0A,监视电池温度变化,当电池温度下降一峰值低约 10℃时,停止实验. At 20±5℃, charging battery with constant current 1C to voltage 4V, then with constant voltage 4V till current decline to 0.	不冒烟,不起火 No explosion, No fire

<p>过放电测试 Over discharge</p>	<p>在 20±5℃状态下, 按标准充电方式充满电后, 静置一小时, 然后用 1C 的电流放电 2.5 小时。 At 20±5℃, the cell are fully charged with standard charging method and standby at least 1 hour. The cell should be discharged at a current of 1C for 2.5h.</p>	<p>不起火,不冒烟,不漏液 No explosion, No fire</p>
<p>短路测试 Short-circuit</p>	<p>在 20±5℃状态下,标准充电后,将电池的正负极用一根小于 50mΩ的导线连接,短路直到电压降至 0.1V 或电芯表面温度降到室温±10℃。 At 20±5℃, The cells are fully charged with standard charging method and standby at least 1hour. Positive and negative terminal connect with wire (maximum load of 50mΩ) to cause short circuit until its voltage is lower than 0.1V or cell temperature on the surface is back to room temperature ±10℃.</p>	<p>不爆炸的,不起火 表面的温度低于 150℃ No explosion, No fire The temperature of the surface of the cell are lower than 150℃</p>
<p>加热测试 Heating</p>	<p>将电池放置在真空箱中, 以每分钟 5±2℃频率加热, 一直到 130℃, 放置 30 分钟。 Battery is heated in a circulating air oven at a rate of 5±2℃ per min to 130℃, an then placed 30 mins at 130℃.</p>	<p>不起火,不冒烟 No explosion, no fire</p>

10. 出货/包装/储存及运输 Delivery/Packing/Storage and Shipment

10.1 正常情况下, 电池出厂前带电量 30-70%, 如有特殊要求, 需提出后确认, 出货电压: 12.8-13.4V.

Approx. 30-70% charged before delivery, Shipment voltage: 12.8-13.4V.

10.2 电池装运前的检查 Pre shipment inspection

对于所有电池, 在装运前需检查其电压、内阻与保护电路的功能.

The battery should be checked the voltage, resistance and the function of protective circuit before shipment.

10.3 包装与运输电池 Packing and Shipping

10.3.1 当电池需要再运输以便在工厂装配时, 要特别注意包装, 以避免运输时产生应力.

The battery should be transported to the factory assembly, to pay special attention to the packing, in order to avoid transport stress.

10.3.2 电池应在半荷电状态包装成箱进行运输, 在运输过程中, 防止剧烈振动、冲击、挤压, 防止日晒雨淋, 应使用汽车、火车、轮船、飞机等交通工具运输.

The battery should be in a half state of charge packaging boxes for transport, in the transport process, prevent severe vibration, shock, extrusion, prevent the sun and rain, should be in automobile, train, ship, airplane and other forms.

10.4 电池异常 Abnormal Condition

不要使用由于运输中应力、跌落、短路或其它原因被损害并发出电解液异味的异常电池。

Do not use the battery when it's smell like abnormal cell electrolyte because of transport stress, sag, short circuit or any other.

11. 电池外观 Battery Pack Feature



备注 Remarks:

1. 尺寸 Dimension: 330*173*215±5mm

HMS Model	LiFePO4 32700 12.8V 100Ah		
File No.	HLFGB040100-0005	Signature	Date

Revision	A0	Drawn by	Roy Cai	2019-03-28
Unit	mm	Checked by		

12. 保质期 Period of Warranty

电池的保质期从出货之日算起为一年.如果证明电池的缺陷是在我们公司制造过程中造成的而不是客户滥用或错误使用造成, 本公司负责退换电池.

The period of warranty is one year from the date of shipment. HIMAX guarantees to give a replacement in case of battery with defects proven due to manufacturing process instead of the customer abuse and misuse.

13. 警告 Warnings

为防止电池可能发生的泄漏,发热,起火,请注意以下预防措施:

To prevent the possibility of the battery from leaking, heating, fire, Please READ this specification carefully before usage and observe the following precautions:

◎**充电时请选用磷酸铁锂电池专用充电器.**

◎电池外包装膜易被镍片,尖针等尖锐部件损伤,禁止用尖锐部件碰伤电池.

◎严禁将电池浸入海水或水中.

◎禁止将电池在热高温源旁,如火,加热器等使用设备.

◎禁止颠倒正负极使用电池.

◎禁止将电池直接接入电源插座.

◎禁止将电池丢入火或加热器中.

◎电池极耳的机械强度不坚固,特别是铝极耳,禁止弯折.

◎禁止用金属直接将电池的正负极进行短路连接.

◎禁止将电池与金属,如发夹,项链等一起运输或贮存.

◎禁止敲击或抛掷,踩踏电池等.

◎禁止直接焊接电池和用钉子或其它利器刺穿电池.

◎禁止擅自拆解电池.

◎**When recharging, use the LiFePO4 battery charger specifically for that purpose.**

◎Do not strike battery with any sharp edge parts, such as Ni-tabs, pins and needles.

◎Do not immerse the battery in water and seawater.

◎Do not use and leave the battery near a heat source as fire or heater.

◎Do not reverse the position and negative terminals.

◎Do not connect the battery to an electrical outlet.

◎Do not discard the battery in fire or heat it.

◎The battery tabs are not so stubborn especially for aluminum tab. Do not bend tab.

◎Do not short-circuit the battery by directly connecting the positive and negative terminal with

metal object.

⊙Do not transport and store the battery together with metal objects such as necklaces, hairpins etc.

⊙Do not knock or throw, trampling battery etc.

⊙Do not directly solder the battery and pierce the battery with a nail or other sharp object.

⊙Do not split the battery without permission.

14. 电池操作说明 Battery operation instruction

14.1 充电 Charging

充电电流：不能超过规格书规定的最大的充电电流

充电电压：不能超过规格书规定的最高的限制电压

充电温度：电池充电温度必须按照规格书的温度范围执行

先恒流后恒压方式充电，禁止颠倒的方式充电.如果电池正负极颠倒充电会带来危险.

Charging current: Do not surpass the biggest charging current which in this specification.

Charging voltage: Do not surpass the highest voltage which in this specification.

Charge temperature: The charge temperature is in according to this specification.

14.2 放电电流 Discharging

电池放电电流不能超过规格书规定的最大放电电流，

过大的电流放电会造成电池发热和容量衰减.

电池放电温度必须按照规格书的温度范围执行.

Discharge current: Do not surpass the biggest discharge current which in this specification.

Discharging with a higher current may result in the capacity fade and over-heat.

Discharge temperature: The discharge temperature is in according to this specification.

14.3 过放电 Over-discharges

短时间的的过充过放不影响电池的使用，但是长时间的过放电会影响到电池的功能失效，电池永久性不能适用，可能电池过放还有一个原因是自动能量的消失.预防电池过放的出现现方法
电池应保持一定的电量.

After the short time excessively discharges charges immediately cannot affect the use, but the long time excessively discharges can cause the battery the performance, battery function losing. The battery long-term has not used, has the possibility to be able to be at because of its automatic flashover characteristic certain excessively discharges the condition, for prevented excessively discharges the occurrence, the battery should maintain the certain electric quantity.

14.4 贮存电池 Storing the Batteries

电池贮存在规格书规定的温度范围内，如果电池贮存超过三个月，建议你开始给电池充电.

The battery should store in the product specification book stipulation temperature range. If has surpasses above for 3 months the long time storage, suggested you should carry on additional

charge to the battery.

14.5 连续充电请不要超过 8 小时.

Please do not continuously charge the battery over 8hours.

15.其他事项 Others

◎客户若需要将电池用于超出文件规定以外的设备，或在文件规定以外的使用条件下使用电池，应事先联系海马士，因为需要进行特定的实验测试以核实电池在该使用条件下的性能及安全性.

◎对于在超出文件规定以外的条件下使用电池而造成的任何意外事故，海马士不负责.

◎如有必要，海马士会以书面形式告之客户有关正确操作使用电池的改进措施.

◎任何本说明书中未提及的事项，须经双方协商确定

◎The customer is requested to contact HIMAX in advance, if and when the customer needs other applications or operating conditions than those described in this document. Additional experimentation may be required to verify performance and safety under such conditions.

◎HIMAX will take no responsibility for any accident when the battery is used under other conditions than those described in this Document.

◎HIMAX will inform, in a written form, the customer of improvement(s) regarding proper use and handing of the battery, if it is deemed necessary.